



Electrolux

Modular Preparation 960 mm Freezer Cupboard with 1 Door

ITEM # _____

MODEL # _____

NAME # _____

SIS # _____

AIA # _____



Electrolux



121952 (TCGES1V7T)

Freezer cupboard with 1 door, 960mm

Short Form Specification

Item No.

Constructed entirely in 304 AISI stainless steel. Base and ceiling pressed with rounded corners. Self-closing hinged door. Easily removable guides, racks and condensate bowl. Temperature range from -20°C/-15°C. Built-in refrigeration unit to operate in ambient temperatures up to +43°C. 50mm high density injected polyurethane foam. CFC and HCFC free. Pre-programmed defrosting cycle with automatic evaporation of condensing water. Fitted with evaporator, fan, thermostatic valve, control panel and digital display. 150mm height-adjustable (0/+90mm) oversized feet (65x65mm) can be removed for masonry installation.

Main Features

- Masonry installation possible by simply removing feet.
- Extremely easy to clean thanks to the smooth edges.
- 50 mm high density injected Polyurethane foam, CFC and HCFC free.
- Long term energy savings thanks to the material's stability.
- Tropicalised refrigerated units (+43°C) even on masonry installation.
- Automatic condensing water evaporation. Pre programmed defrosting cycle.
- Adjustable temperature range from -15 °C to -20 °C to suit meat, fish and dairy storage requirements.
- Self closing stainless steel doors (< 90°).

Construction

- Mounted on 150 mm height adjustable (0/+90 mm) oversized (65x65 mm) feet.
- Telescopic runners to ease extraction of GN containers.
- Base and ceiling pressed with rounded corners (R=12).
- Easy to remove guides, racks and condensate bowl.
- Positioned on extractable guides to facilitate maintenance.
- Constructed entirely in AISI 304 Stainless Steel with Scotch Brite finish.

Optional Accessories

- Stainless steel plinth for end elements, 700mm depth PNC 855837
- Stainless steel runners for 1/1GN grids PNC 855906
- Rilsan grid 1/1GN PNC 855907
- Stainless steel 1/1GN grid PNC 855908

APPROVAL: _____

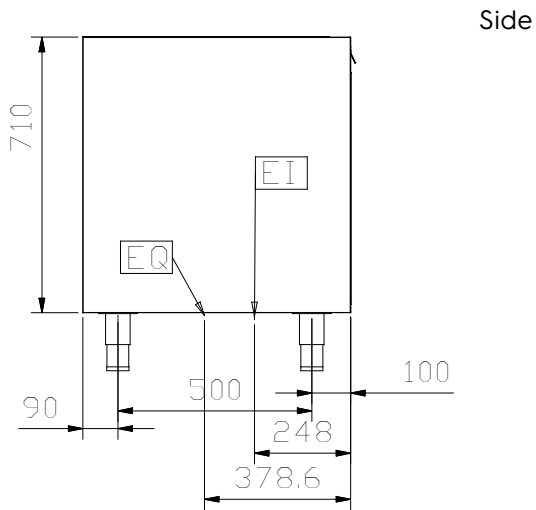
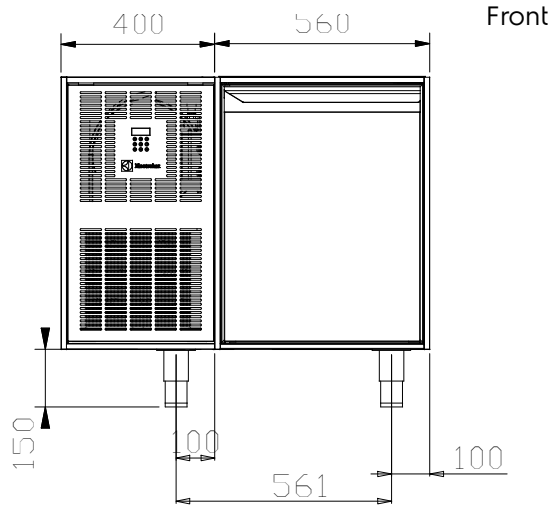

EI = Electrical inlet (power)

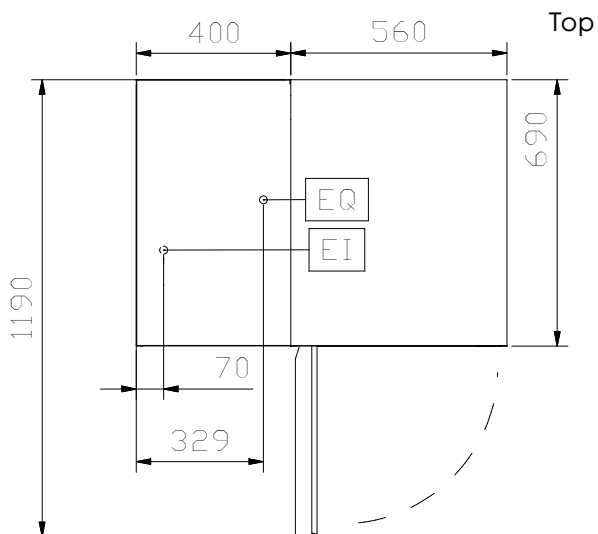

Electric

Supply voltage:

121952 (TCGESIV7T) 230 V/1 ph/50 Hz

Total Watts:

0.62 kW

Key Information:

N° of doors:	1
Door Type:	Hinged
External dimensions, Width:	960 mm
External dimensions, Height:	860 mm
External dimensions, Depth:	690 mm