



Electrolux

Salamander Cookers Electric Salamander, 800mm - Front Opening

ITEM # _____

MODEL # _____

NAME # _____

SIS # _____

AIA # _____



Electrolux



283007 (SCE80MG)

Electric salamander
multigrill, 800mm

Short Form Specification

Item No. _____

Constructed in AISI 430 stainless steel. Table top model. Adjustable grid that can be positioned on 4 levels and can accommodate GN 1/1 containers. Grid equipped with anti-tilt runners and heat resistant handles. Drip tray approx. 7 liters. Closed sides for rapid heating. Control knob for heat regulation.

Main Features

- Table top model with adjustable feet.
- Easy to remove cooking grid and pull-out drip tray of approx. 7 liters.
- Grid equipped with anti-tilt runners and heat-resistant plastic handles.
- Grid can be manually adjusted in 4 different positions between 130mm and 280mm.
- Closed sides for rapid heating and improved safety.
- Large removable cooking grid.
- Compliant to CE requirements for safety.

Construction

- Entirely constructed in 430 AISI stainless steel.
- Top with high intensity heating element.

APPROVAL: _____



Electrolux

Salamander Cookers Electric Salamander, 800mm - Front Opening

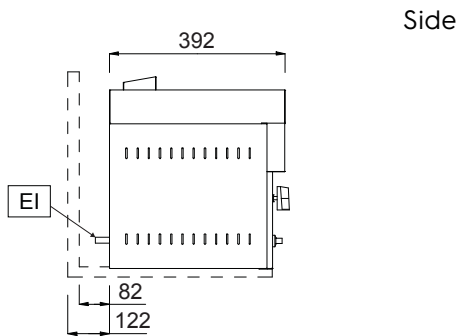
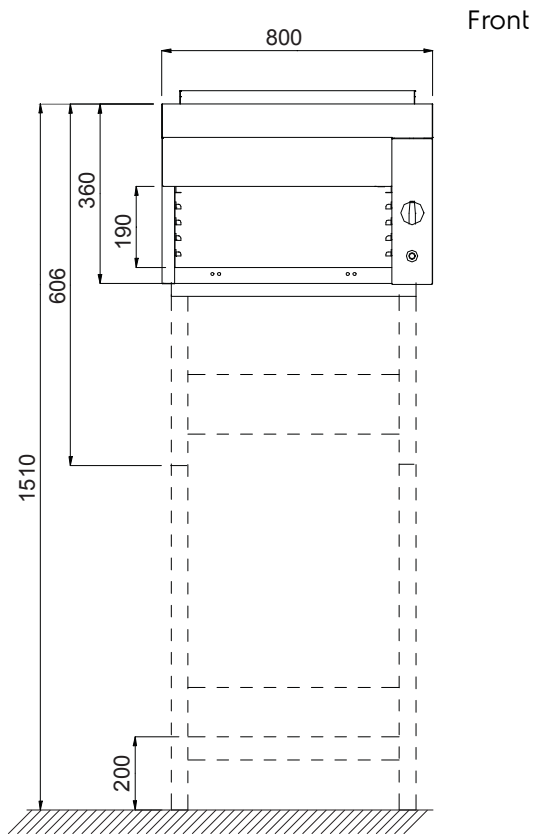

EI = Electrical inlet (power)

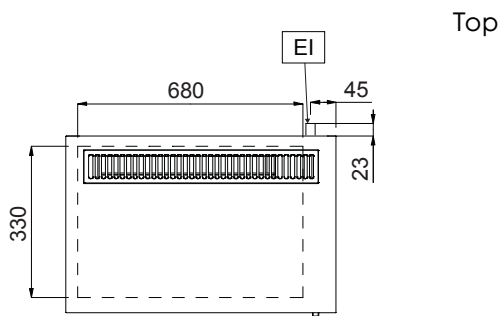

Electric

Supply voltage:

283007 (SCE80MG)

220-240 V/1N ph/50 Hz

Electrical power max.:

5 kW

Installation:

Type of installation:

Countertop; FS on feet; On base; Wall mounted

Key Information:

External dimensions, Width: 800 mm

External dimensions, Height: 390 mm

External dimensions, Depth: 392 mm

N° of grid levels: 5

Salamander Cookers
Electric Salamander, 800mm - Front Opening

The company reserves the right to make modifications to the products without prior notice. All information correct at time of printing.

2018.04.24