



Electrolux

Warewashing Small Double Skin Glasswasher, 1 cycle - 30b/hr

ITEM # _____

MODEL # _____

NAME # _____

SIS # _____

AIA # _____



Electrolux

Warewashing
Small Double Skin Glasswasher, 1 cycle - 30b/hr



402114 (EGWSI)

Glasswasher (small), double skin, 1 cycle, 30b/h

Short Form Specification

Item No. _____

Unit shall be Glasswasher type hot water rinsing for rack dimension of 400*400mm. Electrical characteristics to be 230 single phase operation with one wash cycle of 120 seconds. Rinse temperature and pressure guaranteed by built in pressure boiler. Washing performance is ensured by a powerful wash pump, revolving washing spray arms from both bottom and top. Double skinned counter-balance door. Double skinned cabinet. 304 stainless steel construction to include door, frame, wash tank, wash arms and rinse arms. The unit is equipped with rinse aid dispenser and electric cable with Schuko plug.

Main Features

- Built-in pressure boiler designed to raise incoming water to a guaranteed minimum temperature of 82°C for sanitizing rinse. No external boiler is required.
- Washing system endowed with rotating washing arms from both top and bottom, high powered wash pump and large capacity wash tank guarantee professional washing.
- Maximum capacity of 30 racks per hour.
- 120 seconds cycle.
- Simple operation control panel.
- Solid double skinned counter-balance door with hurt-free handle fully in stainless steel.
- Deep drawn pressed wash tank with fully rounded corners, sloped towards the drain to prevent dirt build up provides fast drainage in only a few minutes. Pressed wash tank with no welded points offer a guaranteed water tight solution.
- Equipped with single phase electrical cable and Schuko plug for easy and fast installation.
- Easy service access to main components without moving the unit.

Construction

- Finished in top quality stainless steel with double skinned construction to aid durability and reduce noise.
- Requires only 1 phase 230V supply.
- Completely closed on the back by a cover plate.
- Unit to feature rinse aid dispenser pump.
- Internal components (arms and filter) are easy extractable.

APPROVAL: _____



Included Accessories

- 1 of Square basket for glasses 400x400x150mm PNC 864470

Optional Accessories

- Stainless steel tank filter PNC 864003
- Filter for partial demineralization PNC 864017
- Kit to measure total and partial water hardness PNC 864050
- Rinse booster pump kit for single tank pressure dishwasher PNC 864051
- Yellow cutlery container PNC 864242
- Filter for total demineralization PNC 864367
- Pressure reducer for single tank dishwasher PNC 864461
- Kit 4 plastic boxes for cutlery - yellow PNC 865574
- Cover rack for small and light items (500x500 baskets) PNC 867016
- Basket for glasses (395x395x115) PNC 867033
- Basket for 16 plates diam.190 mm, 8 plates diam. 240 mm PNC 867052
- Basket for glasses (h 100 mm) PNC 867053
- Basket for glasses (h 200 mm) PNC 867054
- Basket for glasses and saucers/cutlery inserts PNC 867055
- Basket for glasses with angled base PNC 867056
- Round basket kit with square frame PNC 867057
- Insert for "flute" glasses PNC 867058
- Insert for 14 saucers PNC 867060
- Inclined insert for cups PNC 867061
- Insert for 7 plates d. 240mm PNC 867062
- Square basket with angles for glasses 400x400x150 PNC 867067

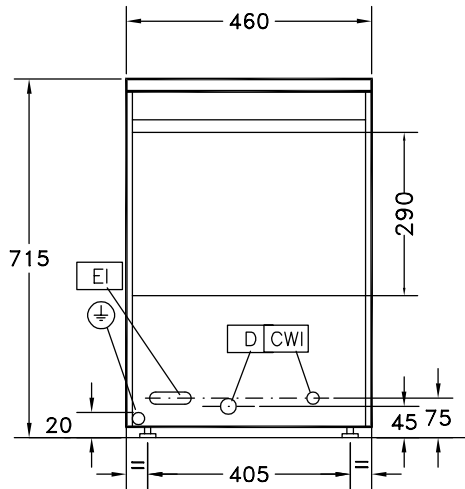
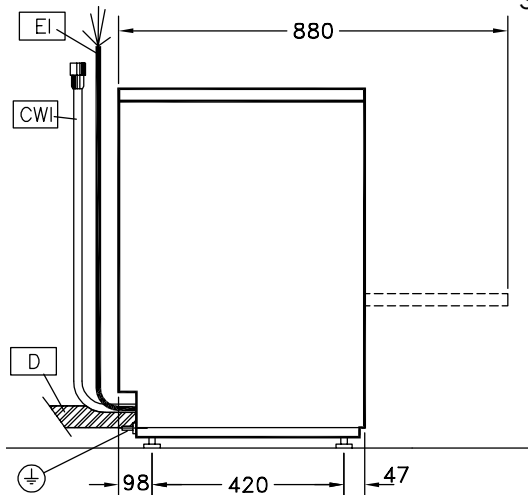

Front

Side

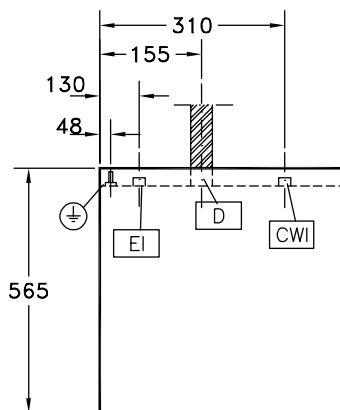
- | | |
|-------------------------------|---------------------------|
| CWII = Cold Water inlet 1 | XD = Detergent connection |
| D = Drain | XR = Rinse aid connection |
| EI = Electrical inlet (power) | |
| EO = Electrical Outlet | |
| V = Air vents | |
| WI = Water inlet | |

Top

Electric

Supply voltage:	
402114 (EGWSI)	230 V/1N ph/50 Hz
Default Installed Power:	3.3 kW
Tank heating elements:	0.8 kW

Water:

Pressure, bar min/max:	1.8-3 bar
Water supply temperature*:	10 °C
Drain line size:	22mm
Boiler Capacity (lt):	5
Incoming water line size:	G 3/4"
Washing tank capacity (lt):	6
Min hot rinse water consumption (lt/cycle)*:	2.3

Key Information:

Baskets per hour:	30
N° of working cycles - sec.:	1 (120)
Cell dimensions - width:	400 mm
Cell dimensions - depth:	400 mm
Cell dimensions - height:	290 mm
External dimensions, Width:	460 mm
External dimensions, Height:	715 mm
External dimensions, Depth:	565 mm
Shipping weight:	42 kg
Shipping height:	900 mm
Shipping width:	620 mm
Shipping depth:	500 mm
Shipping volume:	0.28 m ³
Noise level:	67.5 dBA
Washing cycle temperature:	55-65 °C
Hot rinse cycle temperature:	80-90 °C