



# Electrolux

## Digital Undercounter ecostore HP Premium Refrigerated Counter - 290lt, 4-Drawer, Upstand

ITEM # \_\_\_\_\_

MODEL # \_\_\_\_\_

NAME # \_\_\_\_\_

SIS # \_\_\_\_\_

AIA # \_\_\_\_\_



710019 (EH2H3BB)

4-drawer refrigerated counter 290lt, -2+10°C, AISI 304, with splashback

### Short Form Specification

**Item No.** \_\_\_\_\_

External and internal in AISI 304 stainless steel, galvanized back panel. Worktop thickness 50mm, fitted with integrated rear splashback h=100mm. Insulation thickness 90mm. N. 4X1/2 drawers. Built-in refrigeration unit. Ventilated operating mode. Evaporator. Electronic microprocessor control with external digital temperature display. Automatic defrost. Operating temperature: -2+10°C. CFC and HCFC free. R290 gas in refrigeration circuit. Gas in foam: Cyclopentane.

### Main Features

- Preservation performances and temperature uniformity within the cell guaranteed at 5-HEAVY DUTY (40°C) working conditions according to EN16825:2016 test protocol.
- Adjustable temperature range from -2 °C to +10 °C to suit meat, fish and dairy storage requirements.
- Large digital white-digit display with humidity selection button (3 preset level), internal temperature display and setting, manual activation of defrost cycle and turbo frost cycle (to rapidly cool warm loads).
- Equipped with Optiflow forced air circulation system for rapid cooling and temperature distribution within the cell.
- Tropicalized unit (43°C ambient temperature).
- Fitted with 90 mm thickness of cyclopentane insulation for best insulating performance (thermal conductivity: 0,020 W/m\*K) and lowest environmental impact (GWP=3).
- 0mm clearance installation space: tower configuration cooling unit guarantee performance with frontal ventilation only; this unique solution allows installation against the wall or side by side with other appliances, even on the cooling unit side to maximize the use of kitchen space.
- Frost Watch Control starts automatically the defrosting process only when needed and ends once ice is melted, improving energy efficiency results.
- Combination of doors and drawers to suit any configuration needed, with the possibility to change the configuration on site. Right cooling unit available on request.
- Fully removable cooling unit to facilitate maintenance.
- Frontal and easy access to all components in the cooling unit.
- Fully compliant HACCP digital control: when temperature exceeds critical limits, acoustic and visual alarms are activated. Up to two months of event are kept in memory.
- Anti-tilt runners accept GN 1/1 containers.
- Self closing stainless steel doors (< 90°).
- Certified safety CE requirements.
- Prearranged to fit RS485 port to facilitate connection to a remote computer and integrated HACCP systems.
- Hot gas automatic evaporation of defrost water.
- Hydrocarbon refrigerant gas R290 for the lowest environmental impact (GWP=3) - CFC and HCFC free.

APPROVAL: \_\_\_\_\_



Electrolux

ecostore HP Premium Refrigerated Counter - 290lt, 4-Drawer, Upstand  
Digital Undercounter

### Construction

- Worktop in AISI 304 Stainless steel with a 50 mm profile.
- Raised rear upstand permits unit to be connected up against the wall for better hygiene.
- If needed, working top can be removed for easier handling during installation (in case of narrow doors).
- Anti-drip profile on stainless steel worktop edge.
- Interior base with rounded corners, pressed from a single sheet.
- Ease of cleaning and high hygiene standards thanks to the rounded internal corners, the easily removable runners, grids and air conveyors.
- Removable triple-chamber balloon magnetic gasket to improve insulation and reduce energy consumption and ease of cleaning.
- Internal structure with 15 charging positions (3 cm pitch) available to host GN 1/1 grids, ensuring higher net capacity and a greater storage space.
- Internal and external doors, front and side panels and removable worktop in AISI 304 Stainless steel.
- Mounted on stainless steel feet to give 150 mm (-5/+50 mm) clearance for ease of cleaning the floor.
- External bottom panel in stainless steel.
- External back panel in galvanized steel.
- Built-in refrigeration unit.
- Developed and produced in ISO 9001 and ISO 14001 certified factory.
- Fault code display.
- Internal dimension of the drawers:
  - models with 2 1/2 drawers: 1st drawer (top drawer) 203x302x521 / 2nd drawer 223x302x521 (HxWxD)
  - models with 3 1/3 drawers: 1st drawer (top drawer) 98x302x521 / 2nd and 3rd drawers 118x302x521 (HxWxD)
  - models with 1/3+2/3 drawers: 1st drawer (top drawer) 98x302x521 / 2nd drawer 333x302x521 (HxWxD)

### Optional Accessories

- 2x½ drawer kit for refrigerated counters PNC 881058
- 3x1/3 drawer kit for refrigerated counters PNC 881059
- 1/3 and 2/3 bottle drawer kit for refrigerated counters PNC 881071
- 1/1 GN plastic container, H=65 mm PNC 881110
- 1/1 GN plastic container, H=100 mm PNC 881111
- 1/1 GN plastic container, H=150 mm PNC 881112
- Lock for refrigerated counters with two compartments PNC 881152
- Kit 4 wheels, H=100 mm (2 with brakes) for refrigerated counters PNC 881191
- Kit 4 wheels, H=150 mm (2 with brakes) for 2&3 compartment refrigerated counters PNC 881193

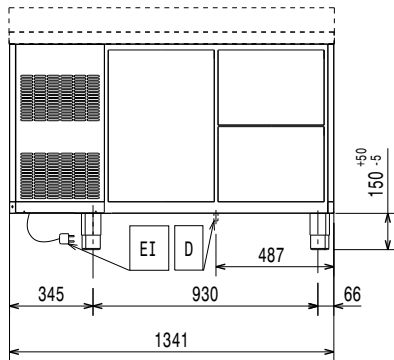
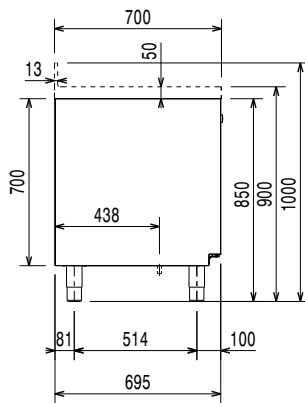
**Front**

**Side**

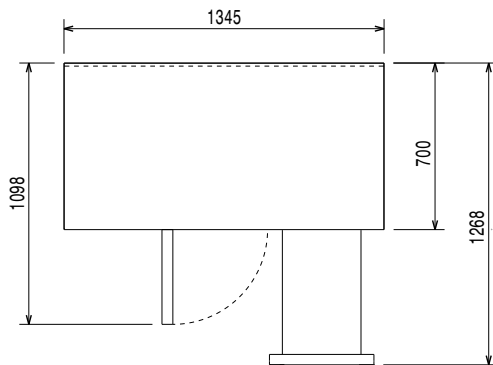
EI = Electrical inlet (power)

**Top**

## Electric

<b>Supply voltage:</b>	710019 (EH2H3BB)	220-240 V/1 ph/50 Hz
<b>Electrical power max.:</b>		0.25 kW
<b>Defrost Power:</b>		0.22 kW
<b>Current consumption:</b>		1.8 Amps
<b>Plug type:</b>		CE-SCHUKO

## Key Information:

<b>Gross capacity:</b>	290 lt
<b>Net Volume:</b>	125 lt
<b>Door hinges:</b>	
<b>External dimensions, Width:</b>	1345 mm
<b>External dimensions, Height:</b>	1000 mm
<b>External dimensions, Depth:</b>	700 mm
<b>Internal Dimensions (depth):</b>	560 mm
<b>Internal Dimensions (height):</b>	550 mm
<b>Internal Dimensions (width):</b>	798 mm
<b>Net weight:</b>	116 kg
<b>Shipping volume:</b>	1.24045 m <sup>3</sup>
<b>Depth with doors open:</b>	1110 mm
<b>Height adjustment:</b>	-5/50 mm

## Refrigeration Data

<b>Control type:</b>	Digital
<b>Compressor power:</b>	1/4 hp
<b>Refrigerant type:</b>	R290
<b>GWP Index:</b>	3
<b>Refrigeration power:</b>	320 W
<b>Refrigeration power at evaporation temperature:</b>	-10 °C
<b>Refrigerant weight:</b>	70 g
<b>Min/Max internal humidity:</b>	40/85
<b>Operating temperature min.:</b>	-2 °C
<b>Operating temperature max.:</b>	10 °C
<b>Operating mode:</b>	Ventilated

## Product Information (EU Regulation 2015/1094)

<b>Energy Class:</b>	B
<b>Yearly and daily energy consumption:</b>	641kWh/year - 1.76kWh/24h
<b>Climate class:</b>	Heavy Duty (5)
<b>Energy Efficiency Index (EEI):</b>	30.40

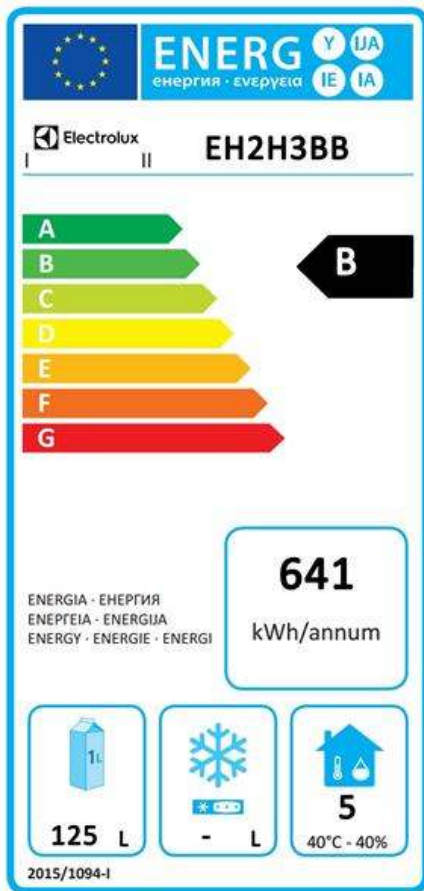

### EU energy labelling from 1st July 2016

The European energy labelling scheme for professional refrigerators and freezers is based on requirements setting Minimum Energy Performance standards for commercial refrigeration cabinets sold within the EU. These requirements are designed to drive energy efficiency and environmentally friendly approach for professionals. The European energy labelling scheme will apply to all manufacturers and importers who sell and market products within the EU and it is mandatory across Europe.

**Important:** all products which consume energy above the minimum level will not be able to be sold within the EU from 1 July 2016.